

Triac dimmable driver---Constant Voltage PWM output series 300W

■Features



- Output constant voltage
- Range AC input: 200-240VA
- Built-in active PFC function
- Efficiency :up to 89%
- Protections:short circuit/over loading/over temperature
- Full protection aluminum housing easy installation
IP66 design for outdoor installation
- Cooling by free air convection
- Work with leading edge and trailing edge TRIAC dimmers
- Strong compatibility, flicker-free dimming
- Suitable for LED lighting and moving sign applications

■ Specification



Model		KVF-12300-TDH	KVF-24300-TDH
Output	DC Voltage	12V	24V
	Voltage Tolerance	±0.5V	
	Rated current	25A	12.5A
	Rated power	300W	
Input	Voltage Range	200-240V AC	
	Frequency Range	47-63HZ	
	Power Factor	PF ≥ 0.97/200VAC PF ≥ 0.97/230VAC PF ≥ 0.97/240VAC(Full loading)	
	Full Load Efficiency(Typ.)	88%	89%
	AC Current (Max.)	2.0A	2.0A
	Leakage current	<0.50mA	
Protection	Short Circuit	shut down o/p voltage, re-power on to recover after fault condition is removed	
	Over load	≤120% Hiccup mode,recovers automatically after fault condition is removed	
	Over Temperature	100℃±10℃ shut down o/p voltage, re-power on to recover	
Environment	Working TEMP.	-40~+60℃ (Refer to Derating Curve -- Page 4)	
	Working Humidity	20~95%RH,non-condensing	
	Storage TEM.,Humidity	-40~+80℃,10~95%RH	
	TEMP.coefficient	±0.03%/℃(0~40℃)	
	Vibration	10 - 500Hz, 5G 12min./1 cycle, period for 72min.each along X,Y,Z axes.	
Safety&EMC	Safety standards	EN61347-1 EN61347-2-13	
	Withstand voltage	I/P-O/P:3.75KVAC I/P-FG:1.88KVAC O/P-FG:0.5KVAC	
	Isolation resistance	I/P-O/P I/P-FG O/P-FG:100MΩ/500VDC/25℃/70%RH	
	EMC EMISSION	EN55015,EN61000-3-2,3 (≥60%loading)	
	EMC Immunity	EN61000-4-2,3,4,5,6 ,11,EN61547	
Others	Weight	1.67kg	
	Size	276*78*47mm(L*W*H)	
	packing	336*121*61mm inner box, 350*310*260mm outside carton 10PCS /CTN	
Notes	1. All parameters NOT specially mentioned are measured at 230VAC input , rated load and 25℃ of ambient temperature. 2. To extend the driver's using life ,please reduce the loading at lower input voltage. 3.Loading range from 10% to 100%		

Triac dimmable driver---Constant Voltage PWM output series 300W

■ Mechanical Specification

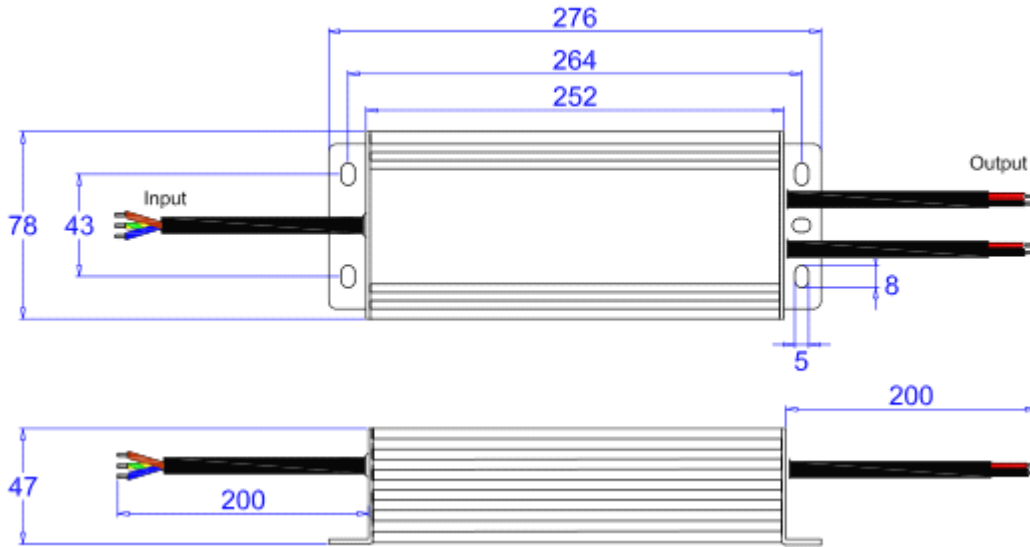

KVF-12300-TDH

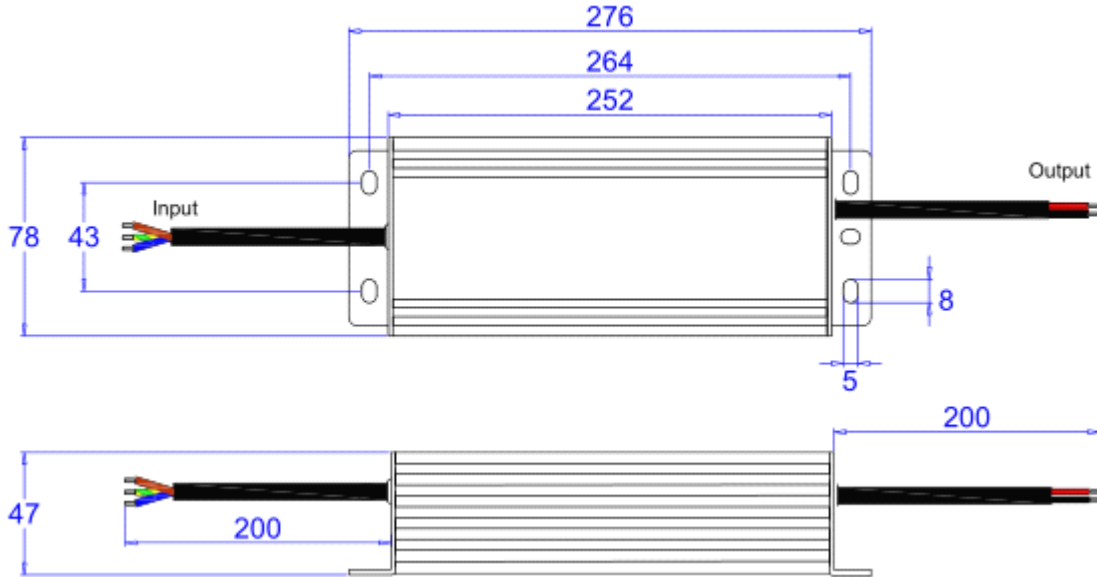

KVF-24300-TDH

- Input**
- L Brown
 - N Blue



Y/G

LED Driver (Triac Dimming - Leading edge and trailing edge)
Constant Voltage

• tc

Model: KVF-12300-TDH
 Input: 200-240V~ 2.0A 50/60Hz
 Output: 12Vrms 25A 300W
 ta:40°C tc:85°C For LED module only



- Output**
- + Red ●
 - Black ●

Triac dimmable driver---Constant Voltage PWM output series 300W

※Input Rubber cable H05VV-F 3*1.0mm² ,the green /yellow cable connect with (FG),Brown with AC (L),Blue with AC(N)

※Output Rubber cable SJTW 14AWG (2*2.08mm²) ,Red is output(V+) Positive,Black is output (V-) negative.Connected to LED Lamps.

※Please make sure you connect these correctly otherwise your product will not function correctly and could be damaged.

※Note: If you have any other requests, we can customized for you.

■Dimming Operation

※Output constant current level can be adjusted through input terminal of the AC phase line(L) by connection a triac dimmer.

※Compatible with Leading edge and tailing edge triac dimmers.

※Please use a dimmer with max. power at least 1.5 times than the load.

■ Connecting Diagram

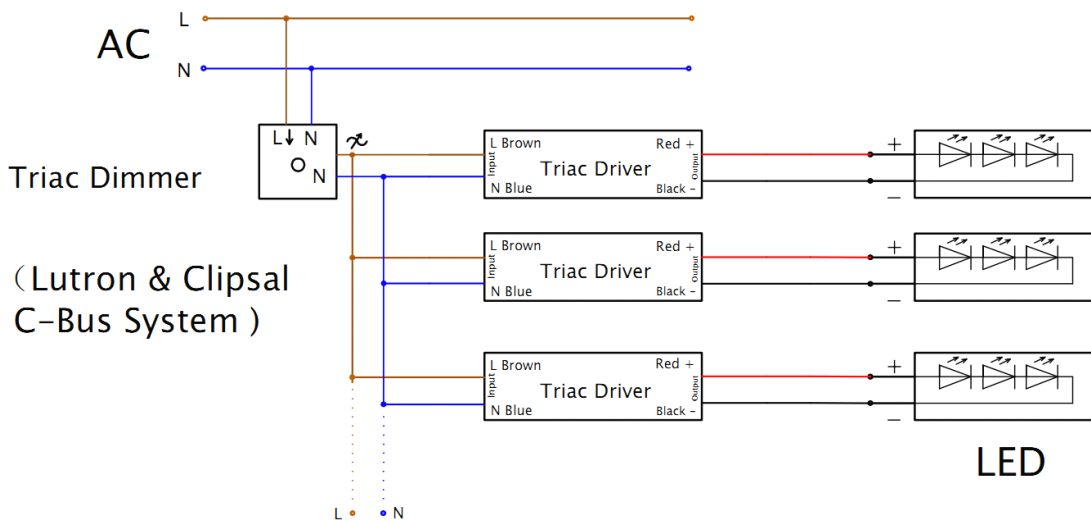
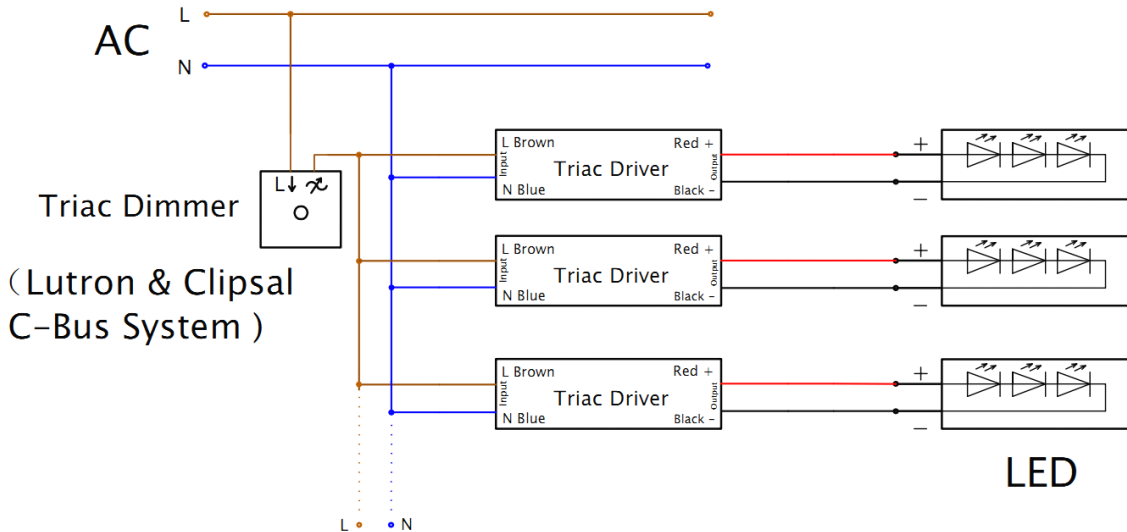

Triac dimmable driver---Constant Voltage PWM output series 300W

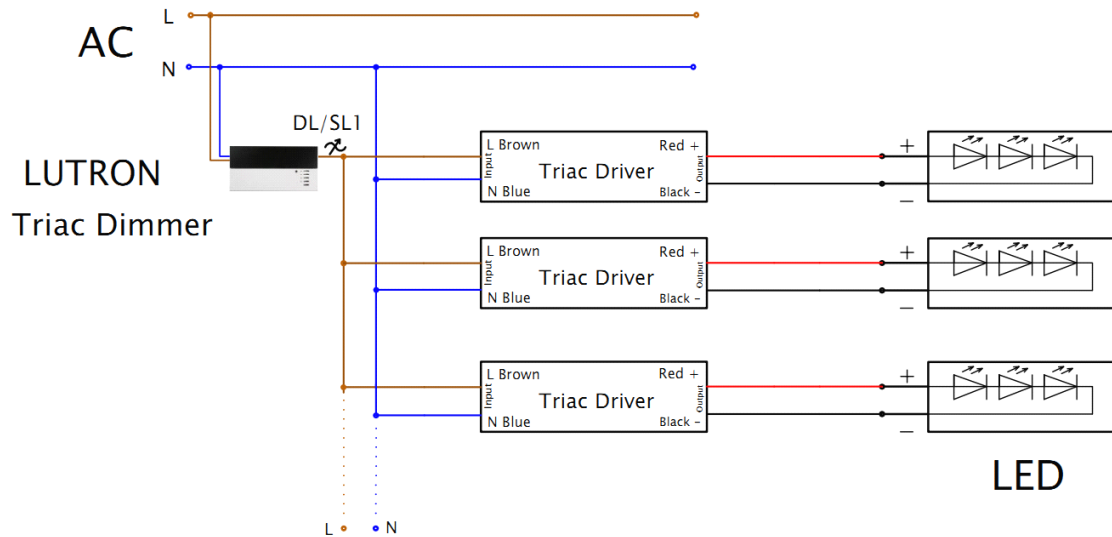

Derating Curve

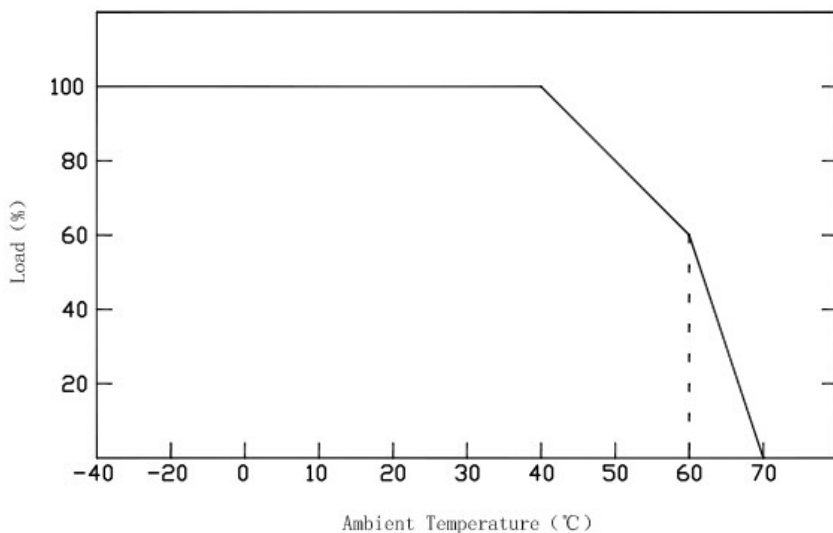

※To extend their life, please refer to the Derating Curve and derate according to the temperature.

Instruction

- 1) This driver should be installed by qualified and professional person;
- 2) Please make sure the transformer is installed with adequate ventilation around it allow for heat dissipation.
- 3) Ensure that wiring is correct before test in order to avoid light and power supply damage;